

Arcadia 48

ELEGANT ESCAPE

The Arcadia's generous scale creates a captivating centerpiece that balances elegance and warmth. Its refined concrete design turns outdoor spaces into inviting sanctuaries.

Weight 350 lbs.

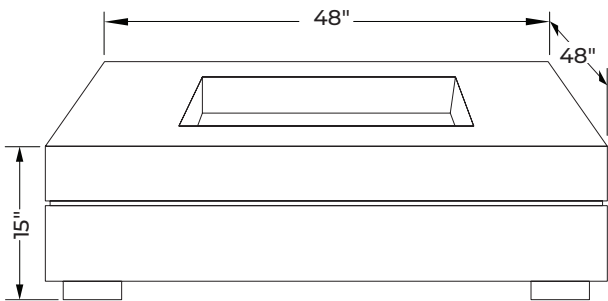

Dimensions
48" x 48" x 15"

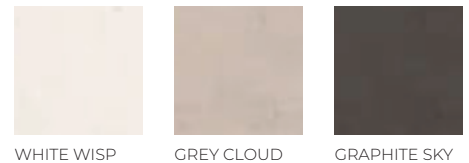

TECHNICAL DATA

Low-Clearance system
(CSA/UL Approved Burner assembly)

Manual

Electronic Ignition

65K BTU NG/LP

140K BTU NG/LP

 For technical information, view the manual
www.dreamcastdesign.com

DreamCast
Design & Production



Please contact us at 1-888-616-4939 with any questions,
or email us at info@dreamcastdesign.com

Arcadia 48

All units ship with either NG/LP burner, lava rock topping and water resistant cover.

TOPPING OPTIONS



RIVER STONES



TUMBLED ROCKS



LOG SETS

EI ACCESSORIES



TIMER



REMOTE



EMERGENCY STOP

To explore more toppings & accessories, visit www.dreamcastdesign.com

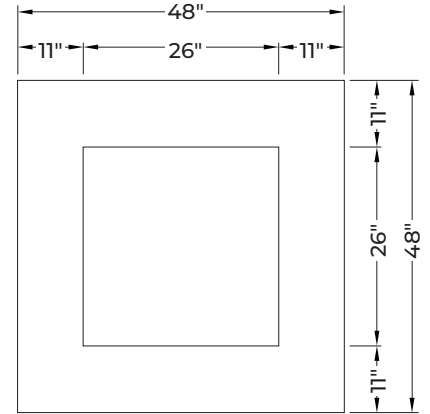

PLAN

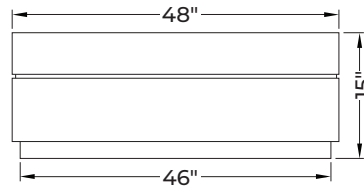

CROSS SECTION

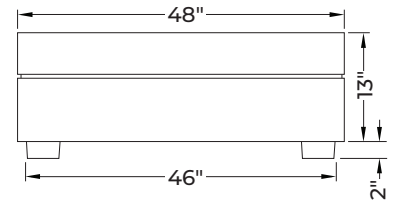

SIDE VIEW - BASE

Min. and Max. Gas Inlet Pressures

The installer is responsible for using the correct fuel lines and/or regulation to provide gas to the fire feature within the specified minimum and maximum gas inlet pressures.

Refer to installation manual for more details

